

BILDA[®]

THE EXPERT CLADDING TECHNOLOGY





BILDA Overview

BILDA is an innovative technology for assembly of structures and mechanical fixing of cladding panels which comprises the following basic components:

BILD-ing kit. A modular set of square profiles, Q-channelled at corners, and versatile elements that can form various structures through quick dovetail coupling – from flat grids to spatial constructions and entire independent structures. These can incorporate mechanically fixed layers to form cladding skins for facades or other applications.

BILDA components are produced from aluminium alloy EN AW 6063-T6.

Cladding method. A precision slot technique that allows for innovative slot-and-blade attachment of the skin elements to the substructure. The precision slot is a minimally invasive cut in the side of the panels that spares their thickness and their strength, respectively. The blades of the fixing clips tie back the panels by penetrating the slots. The 'slot-and-blade' connection also allows for even distribution of stress from horizontal load.

Know-how. Assembly rules, detailing, technical data, instructions and methodology, precision slot milling guidelines – all developed through study, modelling, testing and practice.

bilda.net

Slotting machinery. Patented machinery and tools for milling the precision mortise slots in panels by a low-cost cutting process. A range of efficient rigs for the factory and construction site as well as handheld machines is available.

Features & Advantages

Versatility. The modular set of elements can be used to just cover walls and create simple cladding layers. It can also help model the cladding layer in a 'bas relief' manner or create 'haut relief' features and façade elements.

Low cost. BILDA accomplishes structures of excellent strength-to-cost ratio due to its integrity. Labour time is saved through quick connections. Panel thickness may be reduced via the flat precision slot. Slots are the easiest cladding panel mortise due to machining through cutting.

Universality. A wide range of fixing clips of different size and shape can support panels from all materials, of different thickness and configuration. The clips, in addition to the preferred 'slot-and-blade' method, can handle all known fixing methods - the 'hole-and-dowel', 'undercut' of different types, etc. These can be employed next to each other.

Regulations. BILDA conforms to EN 1990: Eurocode, EN 1991: Eurocode 1, EN 1999: Eurocode 9, DIN 18516-1: 2010-06

Vertical Strut Assembly

Vertical strut assembly is designated mainly for 'landscape' orientation of the cladding panels.



Horizontal Strut Assembly

Horizontal strut assembly is designated mainly for 'portrait' orientation of the cladding panels.



Machine for slotting and drilling of facade cladding panels

Description

The machine makes narrow half-moon precision slots in the sides of facade panels of various materials. The machine is designed for high precision, productivity and ease of use.

It can be easily converted into a machine for drilling holes (in the back or sides) in facade panels with diameters $\varnothing 6$, $\varnothing 8$, $\varnothing 10$ and $\varnothing 12$ mm.

Parts

- Height Adjustment Screw
- Control Panel
- Gauge Line
- Motor Bracket
- Motor (spindle or brushed motor)
- Water Pump
- Multidirectional Rolls
- Guide Rail
- Guide Roller
- Limitation Wheel
- Water Tank

Features

- Robust construction of aluminium alloys and stainless steel;
- Table with multi-directional rollers for smooth rotation of the panels;
- Highly efficient work with diamond cutters for slots and diamond drills for holes;
- Horizontal and vertical adjustment of machining heads for different panel thicknesses;
- Limitation wheels and guide rollers for symmetrical and asymmetrical processing;
- Variants with brush motors and spindle motors.

Advantages

- Easy to operate with minimal technical training of the operator;
- Lightweight, compact and easy to transport;
- Precise and clean slots and holes;
- High performance generates fast return on the initial investment;
- Universal application for various types of panels;
- Easy maintenance and mobility.

For more information on:

bilda.net

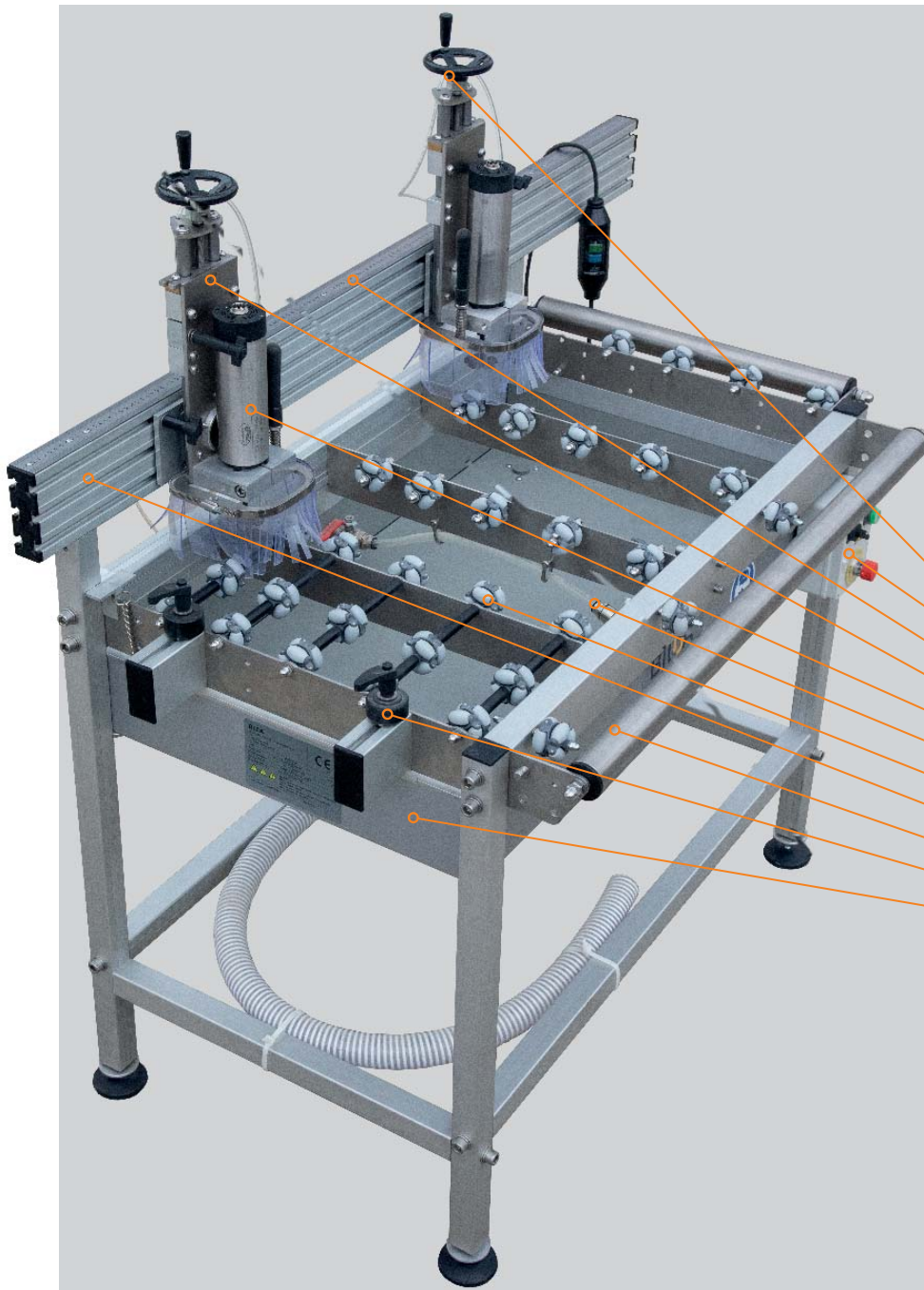

Technical Data

Type	BSD.R1	BSD.R3
DIMS (L*W*H)	1215*705*1060 mm	1465*855*1060 mm
Panel DIMS (W*H)	max. 1500*1000 mm	max. 1750*1200 mm
Variable Speed	ER16 collet $\varnothing 8$ mm	
Power Supply	230 V / 10 A ~50/60 Hz	
Normal Working	min. 0°C, max. 35°C	
Speed of the Motors	3000 min ⁻¹ -18 000 min ⁻¹ for spindle / 4000 min ⁻¹ -25 000 min ⁻¹ for brushed	
Power Rating	3000W for spindle motors / 2100W for brushed motors	
Net Weight	59 kg	76 kg
Slotting Disc	min. $\varnothing 40$ mm, max. $\varnothing 70$ mm	
Drill Bit	$\varnothing 6$ mm, $\varnothing 8$ mm, $\varnothing 10$ mm, $\varnothing 12$ mm	
Table (L*W)	1115 (1315**) * 705 mm	1365 (1565**) * 855 mm
Variable Speed	Yes	
Drilling Depth	25–45 mm (Horizontal/Side), 6–15 mm (Vertical/Back)	
Panel Thickness	min. 8 mm, max. 50 mm	
Slot Thickness	min. 2 mm, max. 10 mm	
** plus 200 mm for asymmetrical slotting and drilling		

Handheld Slotting & Drilling Power Tools

Type

BSD.H – Slotting and Drilling Power Tool

BSD.HS – Slotting and Drilling Power Tool with suction cup

Description

The handheld slotting and drilling power tool makes:

- narrow half-moon precision slots in the sides of façade panels of various materials.
- drilling holes (in the back or sides of the panel) with a diameter of 6, 8, 10 and 12 mm

The power tool is designed for productivity and ease of use. It is guided by hand and incorporates an easy to use visual guiding aid.

Options

- Beam for composition of two power tools;
- For more productivity, two power tools can work together using a special beam. One type or different types (BSD.H plus BSD.HS) of machines can be used.

Features

- Solid and robust frame made from corrosion resistant materials;
- Base plate for easy guiding of the machine over the surface of the cladding panel;
- Highly efficient, fast slotting diamond discs;
- Vertical adjustment of the motor to accommodate varying thickness of all types of panels;
- Easy to adjust visual guiding aid for feeding parallel to the sides of the cladding panel.

Technical Data

Type	BSD.H / BSD.HS
Power Supply	230 V / 5 A ~50/60 Hz
Normal Working	min. 0°C, max. 35°C
Speed of the Motor	from 4000 min ⁻¹ to 25 000 min ⁻¹
Power Rating of the Motor	1050 W
Collet Capacity	ER16 collet Ø6 mm, Ø8 mm
Net Weight	4.7 kg
Slotting Disc	min. Ø40 mm, max. Ø70 mm
Power Cord Length	5 m
Variable Speed	Yes
Panel Thickness	min. 8 mm, max. 60 mm
Slot Thickness	min. 2 mm, max. 10 mm

Advantages

- Easy to operate without any special technical training of the operator;
- Stable and easy to use guiding system;
- Light, compact and easily transportable;
- Slots and holes are produced with precise and clean finish;
- High performance generates fast return on initial investment;
- Universal application for various types of façade panels;
- Easy maintenance and mobility.



Scan to download
BILDA Catalogue

ASIA/ NZ/ AU OFFICE
STOA NZ

T: +64 277788428
E: rado@bildan.z
www.bildan.z

HEAD OFFICE
STOA OOD
61A Kliment Ohridski Blvd.
1756 Sofia, Bulgaria
T: +359 899 992 992
E: bildan@stoa.net
www.bildan.net